

NCF-20-H

COUNTERTOP DISPLAY FREEZER

Ideal for convenience stores, grocery stores and cafés

NEW AIR



FEATURES

Tempered glass door with lock

Manual defrost

LED interior lighting

Aluminum interior

Adjustable PVC shelves

SPECIFICATIONS

Capacity (Cu. ft)	3.0
Capacity (Liters)	88 L
Exterior Dimensions (in)	23 1/2" x 20 1/2" x 25 1/2"
Interior Dimensions (in)	19" x 15 1/2" x 21"
Package Dimensions (in)	25" x 22" x 28"
Net/Gross Weight (lbs)	90 lbs / 99 lbs
Nbr of Shelves	3
Door(s)	1, hinged
Temperature Range (°C)	-9°C TO -23°C
Ambiant Temperature	≤ 30°C
Ambiant Humidity	≤ 55%
Refrigerant (CFC-Free)	R290
Amperage (A)	2.8 A
Voltage (V)	110 - 120 V / 60Hz
Plug Type	NEMA 5-15P

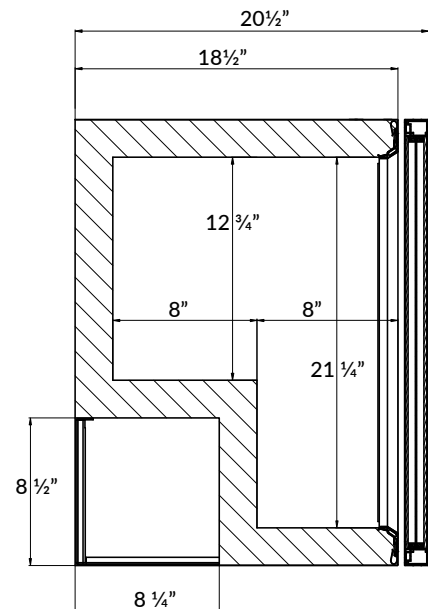
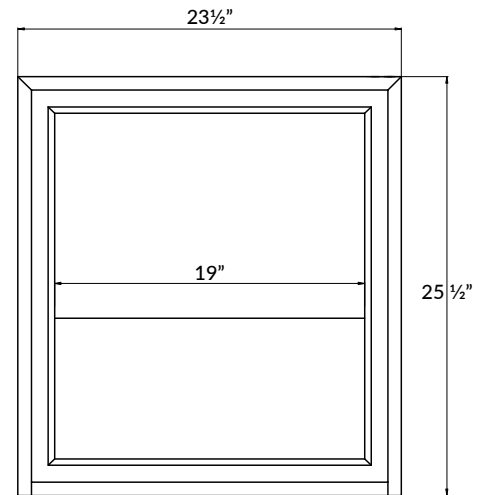

NEW AIR

*Design and specifications may change without prior notice for product improvement

CUSTOMER SUPPORT



1-800-567-3620

NEWAIRREFRIGERATION.CA



2025