

DETAILS & SPECIFICATIONS

SALAD PREP TABLE DSP48-12-D4

Front View

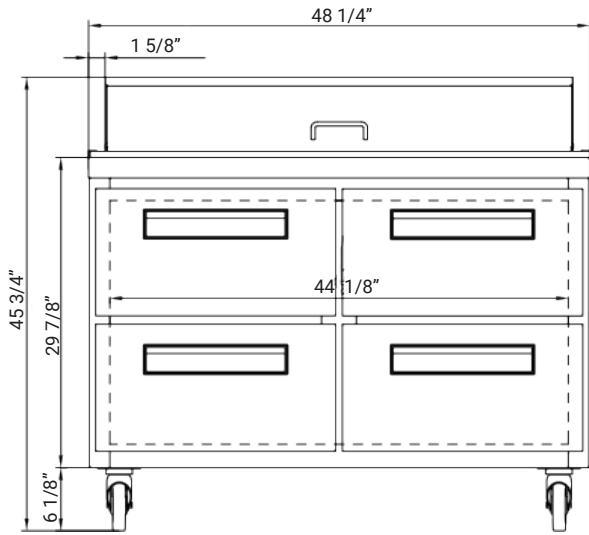

Side View

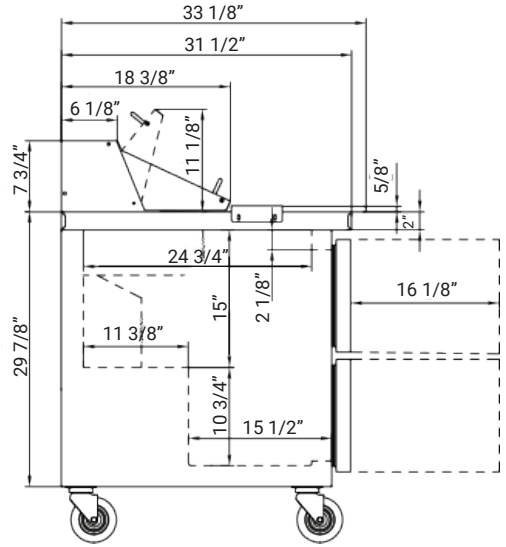

Upper drawer

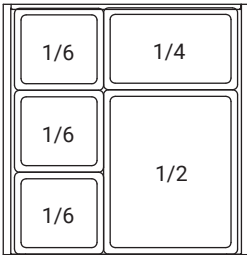

1/6 Pan count: 12



Lower drawer

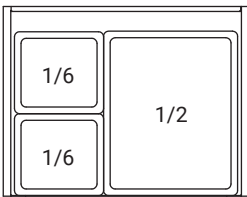

MODEL DSP48-12-D4

| | |
|---------------------------|-------------|
| Cutting Board Size | 48 x 14.5 |
| Rated Voltage | 115V |
| Rated Frequency | 60Hz |
| Total Input Power | 280W |
| Total Current | 2.4A |
| Total Capacity | 11.4 cu ft |
| Climatic Category | 4-5 |
| Protection Type | I |
| Design Pressure High Side | 300 PSIG |
| Design Pressure Low Side | 150 PSIG |
| Insulation Blowing Gas | C-Pentane |
| Refrigerant | R290/3.17oz |

| MODEL | EXTERNAL DIMENSION WXDXH (INCHES) | PACKAGING DIMENSION WXDXH (INCHES) | PRODUCT NET WEIGHT | # OF DRAWERS | 40HQ CONTAINER CERT. |
|-------------|--------------------------------------|---------------------------------------|-----------------------|-----------------|-------------------------|
| DSP48-12-D4 | 48 1/4 x 31 1/2 x 43 5/8 | 52 1/2 x 35 7/8 x 48 3/8 | 231 lbs | 4 | 42 |



AutoQuotes



115/60/1
NEMA-5-15P



Los Angeles | San Francisco | Dallas
Houston | Florida | Chicago | New Jersey

1-800-931-8628

@ info@dukersusa.com

www.DukersUSA.com