

# DETAILS & SPECIFICATIONS

## SALAD PREP TABLE DSP72-18-D6

Front View

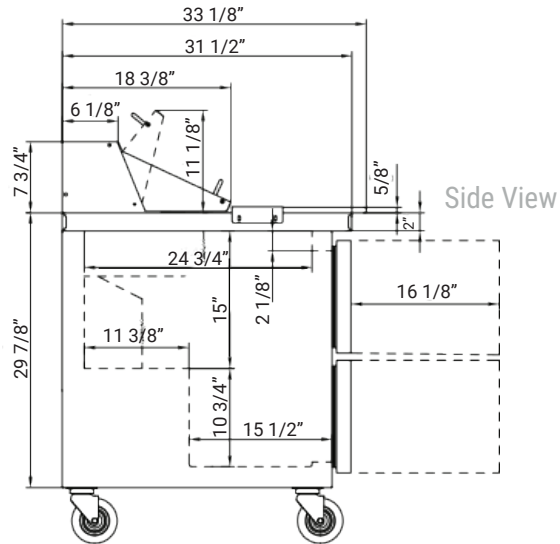
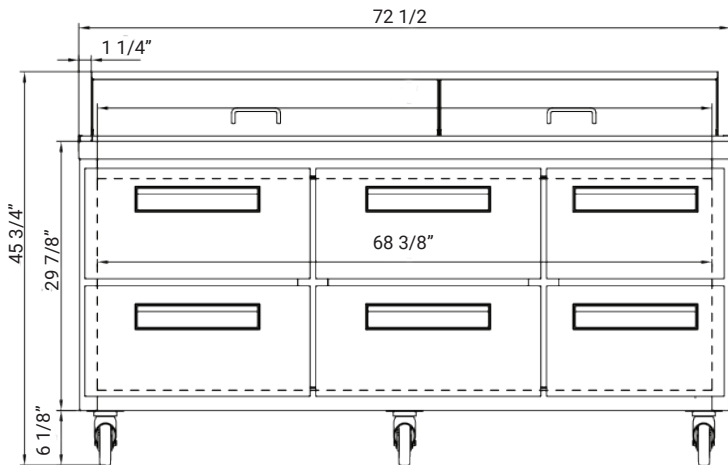

Upper drawer (left/middle)

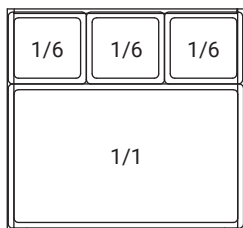

Upper drawer (right)

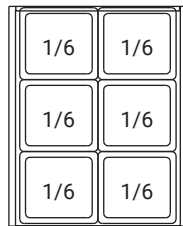

Lower drawer (left/middle)

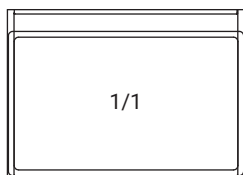

Lower drawer (right)

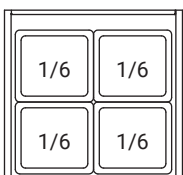

1/6 PAN COUNT: 18

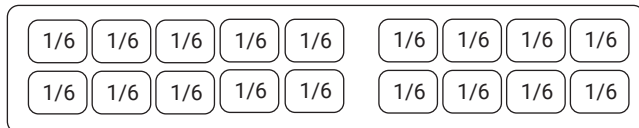

### MODEL DSP72-18-D6

Cutting Board Size	72 x 14.5
Rated Voltage	115V
Rated Frequency	60Hz
Total Input Power	380W
Total Current	3.4A
Total Capacity	17.58 cu ft
Climatic Category	4-5
Protection Type	I
Design Pressure High Side	300 PSIG
Design Pressure Low Side	150 PSIG
Insulation Blowing Gas	C-Pentane
Refrigerant	R290/4.41 oz

MODEL	EXTERNAL DIMENSION WXDXH (INCHES)	PACKAGING DIMENSION WXDXH (INCHES)	PRODUCT NET WEIGHT	# OF DRAWERS	40HQ CONTAINER CERT.
DSP72-18-D6	72 1/2 x 31 1/2 x 43 5/8	76 3/4 x 35 7/8 x 48 3/8	341 lbs	6	26



115/60/1  
NEMA-5-15P



Los Angeles | San Francisco | Dallas  
Houston | Florida | Chicago | New Jersey

1-800-931-8628

@ info@dukersusa.com

www.DukersUSA.com